





Traffic barriers



TRAFFIC BARRIERS

	MAX. BEAM LENGTH	OPENING TIME	CONDITIONS OF USE				FREQUENCY OF USE	BEAM TYPE
			Residential	Condominium	Intensive	Continuous		
PATROL 	4,5 m	5,0 sec. max.	●	●	●	80 %	90x25 Ø80	
ZT 64 	4,5 m	5,0 sec.	●	●	●	70 %	90x25	
ZT 60 	6,5 m	11,0 sec.	●	●		70 %	100x50	
HARRIER-E 	E25=2,5 m E40=4,0 m E50=5,0 m E60=6,0 m	1,8 sec. 2,5 sec. 6,0 sec. 9,5 sec.				● 100 %	90x25 Ø80	
HARRIER-X 	X25=2,5 m X40=4,0 m X50=5,0 m X60=6,0 m	1,8 sec. 2,5 sec. 6,0 sec. 9,5 sec.				● 100 %	90x25 Ø80	

The above mentioned data refer to carefully installed and regularly maintained products.

TRAFFIC BARRIERS



WIRING DIAGRAM

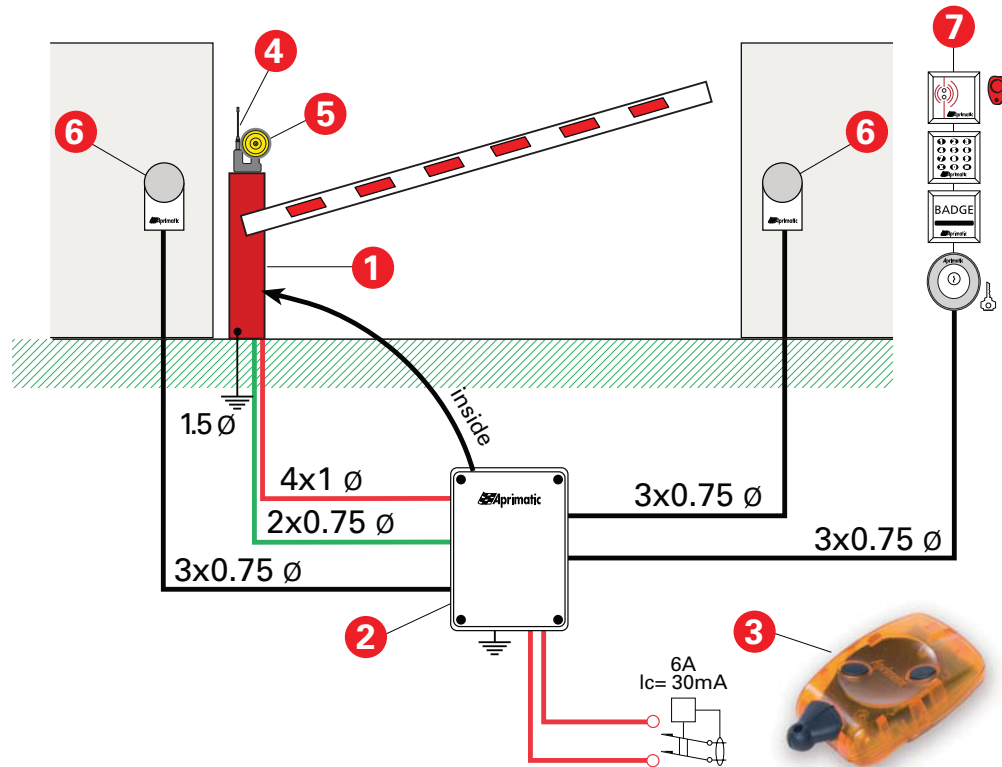

- ① Traffic barrier
- ② Electronic control unit
- ③ Transmitter
- ④ Antenna 433,92 MHz
- ⑤ Flashing light
- ⑥ Pair of photocells
- ⑦ Control device

NOTE: for control and safety devices and installation accessories, see section "Electronic devices and installation accessories" in this catalogue (consult the index).



PATROL



Electro-mechanical 24V barrier
for passage spans of 2 m to 4,5 m.
Intensive use with duty cycle 80%.



Easy access to control unit
for wiring and programming.



User friendly electronics:
easy programming, to set and control,
thanks to the provided display.

Easy to install and setup: all you have to do
is balance the compression spring. A spring
type is available for each barrier length.
Only one model for right and left barrier.

Technical solutions:

- 1) Super smooth action thanks to the spring-loaded balancing system.
- 2) Strong construction featuring a steel load-bearing framework.
- 3) Safe, easy to release system with personalized key.
- 4) Advanced electronics with state-of-the-art programming features.
- 5) Ready for master-slave operation to control twin barriers.
- 6) Long service life guaranteed by the safety slowdown function where microswitch control prevents forcing of mechanical components if the system is incorrectly programmed.

Compact size and latest generation design:
stretched and narrow shape, with a cover
integrating the flashing light.

Intended use:
small / medium car park for private and industrial use.

TECHNICAL DATA

POWER SUPPLY	230 V - 50/60 Hz
MOTOR POWER SUPPLY	24 Vcc
MAX. ABSORBED POWER	150 W
MAX. ABSORBED CURRENT	5 A
MAX. TORQUE	500 Nm
OPENING TIME	5 sec. max.
OPERATING TEMPERATURE	-20°C to +70°C
BEAM LENGTH	from 2,0 to 4,5 m max.
SLOWDOWN	YES (adjustable)
ANTI-CRUSH	YES
PROTECTION CLASS	IP 44

PATROL



OPERATOR DIMENSIONS

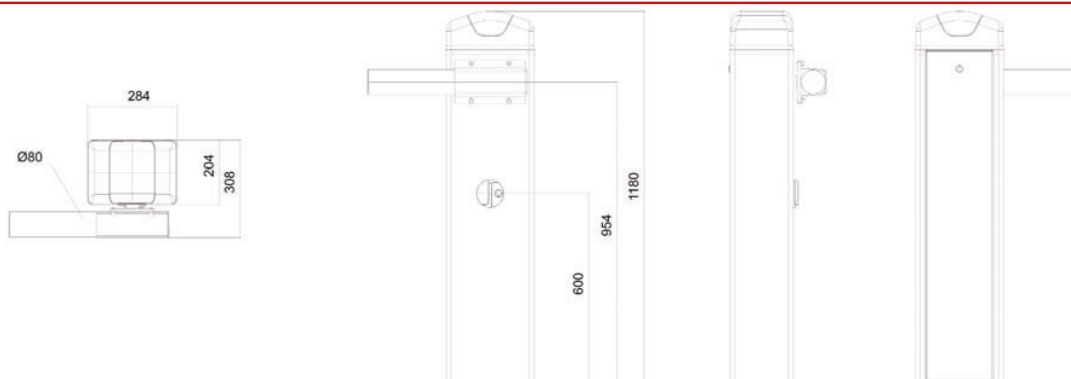

DESCRIPTION	CODE
PATROL with control unit and plug-in radio receiver	41540/001
DESCRIPTION NECESSARY ACCESSORIES	
PF PATROL Base plate	41540/050
Stainless steel securing flange for 90x25 beam	41540/051
Stainless steel securing flange for Ø 80 beam	41540/052
BEAM 90X25:	
- Beam length 2,0 m (for spring combination see table)	41518/001
- Beam length 2,5 m (for spring combination see table)	41518/002
- Beam length 3,0 m (for spring combination see table)	41518/003
- Beam length 3,5 m (for spring combination see table)	41518/004
- Beam length 4,0 m (for spring combination see table)	41518/005
- Beam length 4,5 m (for spring combination see table)	41518/006
BEAM Ø 80:	
- Beam length 3,0 m (for spring combination see table)	41522/001
- Beam length 6,0 m (for spring combination see table)	41522/002
SPRINGS:	
- Patrol "Green" spring	41514/053
- Patrol "Blu" spring	41514/054
- Patrol "Red" spring	41514/055
- Patrol "Yellow" spring	41514/056

DESCRIPTION OF OPTIONAL ACCESSORIES	CODE
Card for double Patrol operation	41540/053
TR2 - Twin-channel transmitter 433,92 MHz	41903/002
FC1 - Fork support for beam	41503/052
PP - Swinging tip support	41504/055
PC12E - Key switch for wall mounting	41830/007
CPC - Key switch column	41830/051
Aprimatic beam stickers (pack of 50 stickers)	41590/106
SKIRT :	
Vertical skirt module (height 69 cm, number of vertical modules to order=beam lengthx2)	41504/051
Horizontal skirt module (wheel base distance 46 cm) number of horizontal modules to order=number of vertical modules-1)	41504/052

SPRING SELECTION TABLE	Length of beam (m)					
	2	2,5	3	3,5	4	4,5
90x25 beam	Green	Green	Blue	Blue	Blue	Yellow
90x25 beam with swing support	Green	Green	Blue	Blue	Blue	Yellow
90x25 beam with skirt		Green	Blue	Red		
Rounded beam Ø 80	Green	Green	Blue	Blue	Blue	Yellow

NOTE: for control and safety devices and installation accessories, see section "Electronic devices and installation accessories" in this catalogue (consult the index).



ZT 64

Hydraulic barrier for vehicular spans of up to 4.5 m.
Residential and condominium use.



■ **High quality barrier** for intensive applications.

■ **Maximum safety** guaranteed by the adjustable anti-crush system with ultra-sensitive bypass valves.

■ **Hydraulic system and helical spring** balancing for smooth and adjustable movement.

■ **Double hydraulic** locking prevents reverse movement when the barrier is closed and also allows to stop the barrier in intermediate positions.

■ **Lightweight aluminium** alloy beam with rubber safety strip to prevent knocks and scratches.

TECHNICAL DATA

POWER SUPPLY	230 V - 50/60 Hz
ABSORBED POWER	250 W
ABSORBED CURRENT	1,6 A
MAX. TORQUE	240 Nm
OPENING TIME	5 sec.
OPERATING TEMPERATURE	-20°C to +70°C
WEIGHT WITH OIL	50 kg
QUANTITY OF OIL	1,6 Lt
TYPE OF OIL	AprimOil HC 13
MAX. OPERATING PRESSURE	40 bar
PUMP CAPACITY	1 Lt/min.
ROTATION ANGLE	90°
BEAM LENGTH	3,0 m-3,5m-4,0 m-4,5 m
PROTECTION CLASS	IP 54

ZT 64



MODEL ZT 64

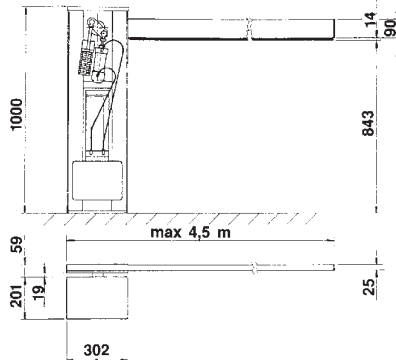

DEFINITION OF RIGHT AND LEFT HAND BARRIERS

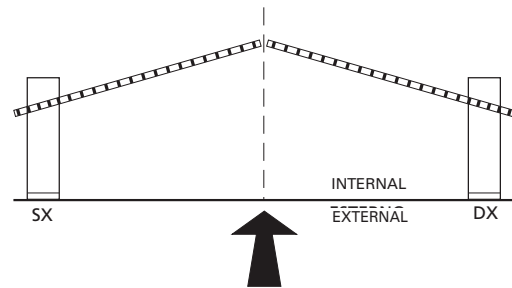

When entering through the barrier, RH barriers open clockwise while LH barriers open anti-clockwise.

DESCRIPTION

DESCRIPTION	Max. beam length	CODE
ZT 64 RH, on-board T3 control unit	4,5 m	41504/002.0
ZT 64 LH, on-board T3 control unit	4,5 m	41504/002.1
ZT 64 RH slave	4,5 m	41504/001.0
ZT 64 LH slave	4,5 m	41504/001.1
ZT 64 Stainless steel RH slave	4,5 m	41504/700.0
ZT 64 Stainless steel LH slave	4,5 m	41504/700.1

All models are equipped with double hydraulic locking and a 90x25 beam fixing bracket.

DESCRIPTION OF OPTIONAL ACCESSORIES

DESCRIPTION OF OPTIONAL ACCESSORIES	CODE
TR2 - 433.92 MHz twin-channel transmitter	41903/002
PC12E - Key switch for wall mounting	41830/007
CPC - Key switch column	41830/051
FC2 - Fork for 2 m to 4.5 m beams	41504/053
PP - Swinging tip support	41504/055
MG90 - Join clamp for 90x25 beams	41504/054
SBS 64 - Articulated beam set	41504/057
SKIRT:	
- Vertical skirt module (height 69 cm, number of vertical modules to order = beam length x 2)	41504/051
- Horizontal skirt module (wheel base distance 46 cm, number of horizontal modules to order = number of vertical modules - 1)	41504/052
Aprimatic beam stickers (pack of 50 stickers)	41590/106

IDEAL INSTALLATION

IDEAL INSTALLATION	Q.ty	CODE
ZT 64 RH on-board T3 control unit	1	41504/002.0
PF 64 - Column base plate	1	41504/056
ER4N - Pair of photocells	1	41812/001
One TR2 - 433,92 MHz twin-channel transmitter	1	41903/002
Unico 433,92 MHz Memory System radio receiver with antenna included	1	41923/009
ET20N - 230 V flashing light	1	41841/009
Necessary accessory: 90x25 beam		
- 3,0 m beam	1	41518/003
- 3,5 m beam	or 1	41518/004
- 4,0 m beam	or 1	41518/005
- 4,5 m beam	or 1	41518/006

NOTE: for control and safety devices and installation accessories, see section "Electronic devices and installation accessories" in this catalogue (consult the index).



ZT 60

Hydraulic barrier for vehicular spans of 5 to 6.5 m.
Residential and condominium.



■ **High quality barrier** for intensive use applications.

■ **Maximum safety** guaranteed by the adjustable anti-crush system with ultra-sensitive bypass valves.

■ **Hydraulic system and helical spring** balancing for smooth and adjustable movement.

■ **Double hydraulic** locking prevents reverse movement when the barrier is closed and also allows to stop the barrier in intermediate positions.

■ **Lightweight aluminium** alloy beam, with rubber safety strip to prevent knocks and scratches.

TECHNICAL DATA

POWER SUPPLY	230 V - 50/60 Hz
ABSORBED POWER	250 W
ABSORBED CURRENT	1,6 A
MAX. TORQUE	230 Nm
OPENING TIME	11 sec.
OPERATING TEMPERATURE	-20°C to +70°C
WEIGHT WITH OIL	85 kg
QUANTITY OF OIL	1,6 Lt
TYPE OF OIL	AprimOil HC 13
MAX. OPERATING PRESSURE	40 bar
PUMP CAPACITY	1 Lt/min.
ROTATION ANGLE	90°
BEAM LENGTH	5,0 m - 5,5 m - 6,0 m - 6,5 m
PROTECTION CLASS	IP 54

ZT 60



MODEL ZT 64

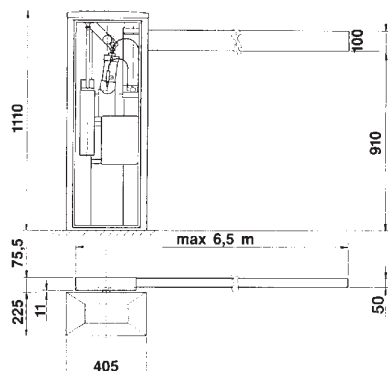

DEFINITION OF RIGHT AND LEFT HAND BARRIERS

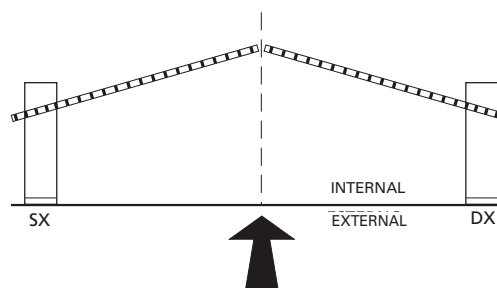

When entering through the barrier, RH barriers open clockwise while LH barriers open anti-clockwise.

DESCRIPTION

DESCRIPTION	Max. beam length	CODE
ZT 60 RH, on-board T3 control unit	From 5 m to 6,5 m	41503/002.0
ZT 60 LH, on-board T3 control unit	From 5 m to 6,5 m	41503/002.1
ZT 60 RH slave	From 5 m to 6,5 m	41503/001.0
ZT 60 LH slave	From 5 m to 6,5 m	41503/001.1
ZT 60 stainless steel RH slave	From 5 m to 6,5 m	41503/700.0
ZT 60 stainless steel LH slave	From 5 m to 6,5 m	41503/700.1

All models are equipped with double hydraulic locking and a 100x50 beam fixing bracket.

DESCRIPTION OF OPTIONAL ACCESSORIES

DESCRIPTION OF OPTIONAL ACCESSORIES	CODE
TR2 - 433.92 MHz twin-channel transmitter	41903/002
PC12E - Key switch for wall mounting	41830/007
CPC - Key switch column	41830/051
AT 60 - Balancing spring for 6,5 m beam	41500/114
FC1 - Fork for 5 m to 6,5 m beams	41503/052
PFF FC60 - Fork base plate	41812/051
PP - Swinging tip support	41504/055
MG100 - Join clamp for 100x50 beams	41503/054
Aprimatic beam stickers (pack of 50 stickers)	41590/106

IDEAL INSTALLATION

IDEAL INSTALLATION	Q.ty	CODE
ZT 60 RH - On-board T3 control	1	41503/002.0
PF 60 - Column base plate	1	41503/053
ER4N - Pair of photocells	1	41812/001
One TR2 - 433,92 MHz twin-channel transmitter	1	41903/002
Unico 433,92 MHz Memory System radio receiver with antenna included	1	41923/009
ET20N - 230V flashing light	1	41841/009
Necessary accessory: 100X50 beam		
- 5,0 m beam	1	41519/006
- 5,5 m beam	or 1	41519/007
- 6,0 m beam	or 1	41519/008
- 6,5 m beam (requires AT 60 balancing spring)	or 1	41519/009

NOTE: for control and safety devices and installation accessories, see section "Electronic devices and installation accessories" in this catalogue (consult the index).



HARRIER

Electro-mechanical barriers
for speed vehicular spans of 2,5 to 6.0 m.
Continuous use with duty cycle 100%.



■ **Stell barrier designed** for continuous use, 1500 cycles per day. 2 versions available: with stainless steel and red epoxy painted body.

■ **Same code for right and left hand barrier**, the installer can change it very easily during installation.

■ **4 barrier models** for each version (E and X) with beams from 2,5 up to 6,0 m and opening speed from 1,8 to 9,5 sec.

■ Both 90x25mm beam and round Ø 80 mm beam are available.

■ **Double microswitch**, for opening and closing maneuvers.

■ **Kinematical glipho**, guarantees the mechanical slowing down.

TECHNICAL DATA	X25-E25	X40-E40	X50-E50	X60-E60
POWER SUPPLY	230 Vac - 50/60 Hz			
ABSORBED POWER	0,18 kW	0,18 kW	0,18 kW	0,18 kW
ABSORBED CURRENT	1,6 A	1,6 A	1,6 A	1,55 A
MAX. TORQUE	40 Nm	70 Nm	120 Nm	160 Nm
OPENING TIME	1,8 sec.	2,5 sec.	6,0 sec.	9,5 sec.
MAX. BEAM LENGTH	2,5 m	4,0 m	5,0 m	6,0 m
OPERATING TEMPERATURE	-15°C to +60°C			

HARRIER



DESCRIPTION	Max. beam length	CODE
E 25 with integrated T5SB unit	2,5 m	41514/001
E 40 with integrated T5SB unit	4,0 m	41514/002
E 50 with integrated T5SB unit	5,0 m	41514/004
E 60 with integrated T5SB unit	6,0 m	41514/003
X 25 STAINLESS STEEL with integrated T5SB unit	2,5 m	41514/701
X 40 STAINLESS STEEL with integrated T5SB unit	4,0 m	41514/702
X 50 STAINLESS STEEL with integrated T5SB unit	5,0 m	41514/704
X 60 STAINLESS STEEL with integrated T5SB unit	6,0 m	41514/703

DESCRIPTION OF OPTIONAL ACCESSORIES	CODE
PF HARRIER Base plate	41514/050
Stainless steel securing flange for 90 x 25 beam	41514/051
Stainless steel securing flange for Ø 80 beam	41514/052
BEAM 90X25:	
- Beam length 2,5 m (for spring combination see table)	41518/002
- Beam length 3,0 m (for spring combination see table)	41518/003
- Beam length 3,5 m (for spring combination see table)	41518/004
- Beam length 4,0 m (for spring combination see table)	41518/005
- Beam length 4,5 m (for spring combination see table)	41518/006
BEAM Ø 80:	
- Beam length 3,0 m (for spring combination see table)	41522/001
- Beam length 6,0 m (for spring combination see table)	41522/002
Telescopic beam from 4,5 m to 6 m (for spring combination see table)	41523/001
SPRINGS:	
- Harrier "Green" spring	41514/053
- Harrier "Blu" spring	41514/054
- Harrier "Red" spring	41514/055
- Harrier "Yellow" spring	41514/056

DESCRIPTION OF OPTIONAL ACCESSORIES	CODE
TR2 - 433.92 MHz twin-channel transmitter	41903/002
433,92 - MHz RR SE Radioreceiver Memory System	41923/009
FC HARRIER fork support for 2 m to 6,0 m beams	41514/057
CPC - Key switch column	41830/051
Aprimatic beam stickers (pack of 50 stickers)	41590/106
PP - Swinging tip support	41504/055
SKIRT:	
Vertical skirt module (height 69 cm, number of vertical modules to order = beam length x 2)	41504/051
Horizontal skirt module (wheel base distance 46 cm, number of horizontal modules to order = number of vertical modules - 1)	41504/052

SPRING SELECTION TABLE	Length of beam (m)									
	2	2,5	3	3,5	4	4,5	5	5,5	6	
90 x 25 beam with impact protection rubber	E25/E40	E25/E40	E40	E40	E40/E50	E50				
90 x 25 beam with rubber and swing support	E25/E40	E25/E40	E40	E40	E40/E50	E50				
90 x 25 beam with skirt		E40	E40/E50	E50	E50	E60				
Rounded beam Ø 80	E25/E40	E25/E40	E40	E40	E40/E50	E50	E50/E60	E60	E60	E60
Rounded telescopic beam						E50	E50/E60	E60	E60	E60

NOTE: for control and safety devices and installation accessories, see section "Electronic devices and installation accessories" in this catalogue (consult the index).



HARRIER

DIMENSIONS

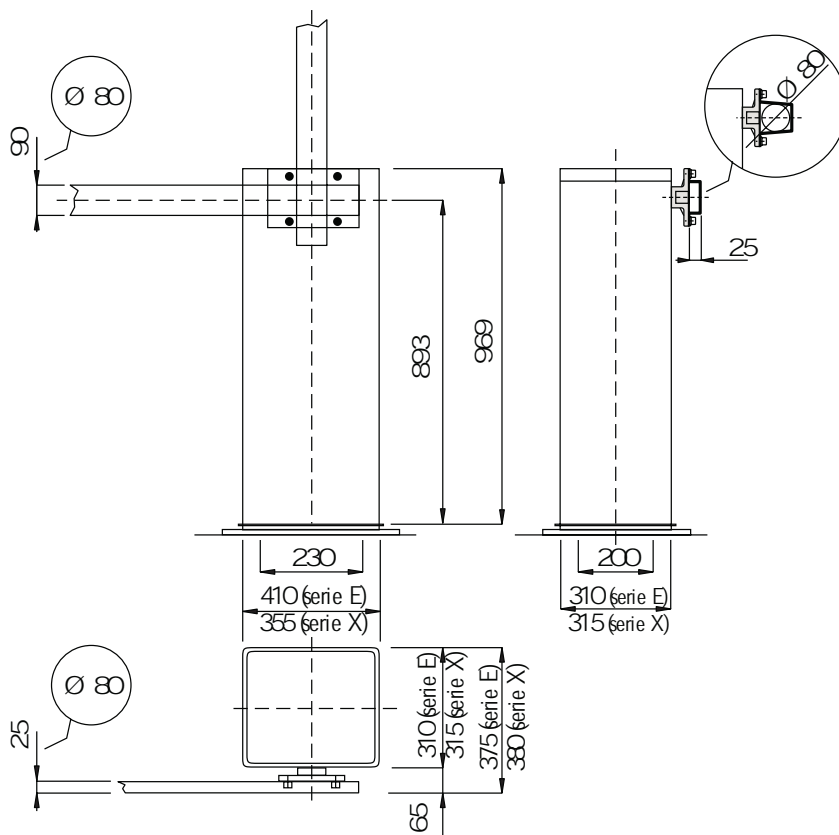

OPENING DIRECTION REVERSAL

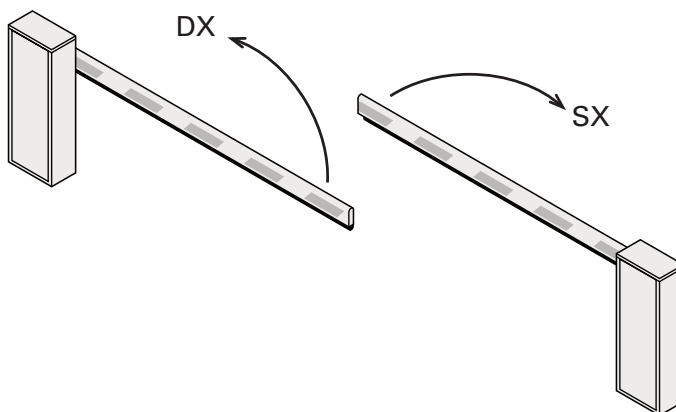

Easy changing of opening direction.

A few simple operations are all that is required to change the Harrier barrier opening direction from R/H to L/H.

The T5SB control unit simplifies this operation even further.

A single jumper reverses the OPEN/CLOSE commands of the motor and OPENING/CLOSING limit switches without having to modify the wiring.



New photocell test function.

To improve the safety of the automation, the T5SB control unit, has been equipped by a new safety device test function.

A photocell function test is performed before any closing operation.

The beam will close only if the test is successful.

SAFETY TEST PROTOCOL

Disconnect the photocell emitter from the power supply.



Check that the contact on the photocell receiver opens.



Connect the photocell transmitter to the power supply.



Check that the contact on the photocell receiver closes.



If everything is OK then closing can take place.

The receiver and transmitter photocells must be powered separately in order to get a reliable test result.

To this end the T5SB control unit is equipped with an extra terminal.

This function can also be used with ER-REF polarised light reflective photocells.

These photocells are already equipped with a special input for this test.

STANDARD CONFIGURATION

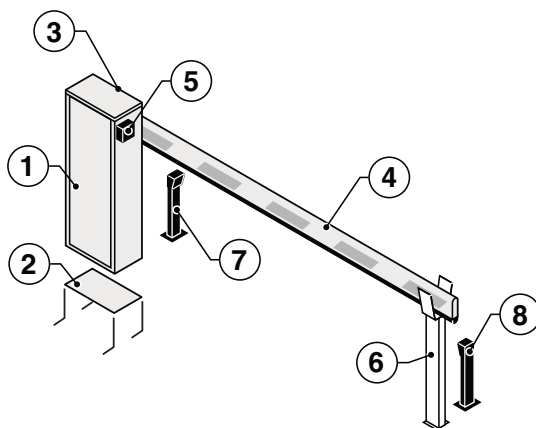

- 1 Harrier barrier
- 2 Base plate
- 3 Fixing bracket 90x25
Fixing bracket Ø 80
- 4 Beam
- 5 Key switch
- 6 Fork support
- 7 Photocell column
- 8 Photocells or polarised reflec. photocells

IDEAL INSTALLATION

	CODE
E 50 - Integrated T5SB unit	41514/004
Beam 90x25 length 4,5 m	41518/006
Stainless steel securing flange for 90 x 25 beam	41514/051
Harrier "Red" spring	41514/055
PF HARRIER Base plate	41514/050
EK24 433 - Elettrokitt 433,92 MHz	41700/007